

# REINHARDT

## System- und Messelectronic GmbH

### Weather and Environment Sensors Series 55

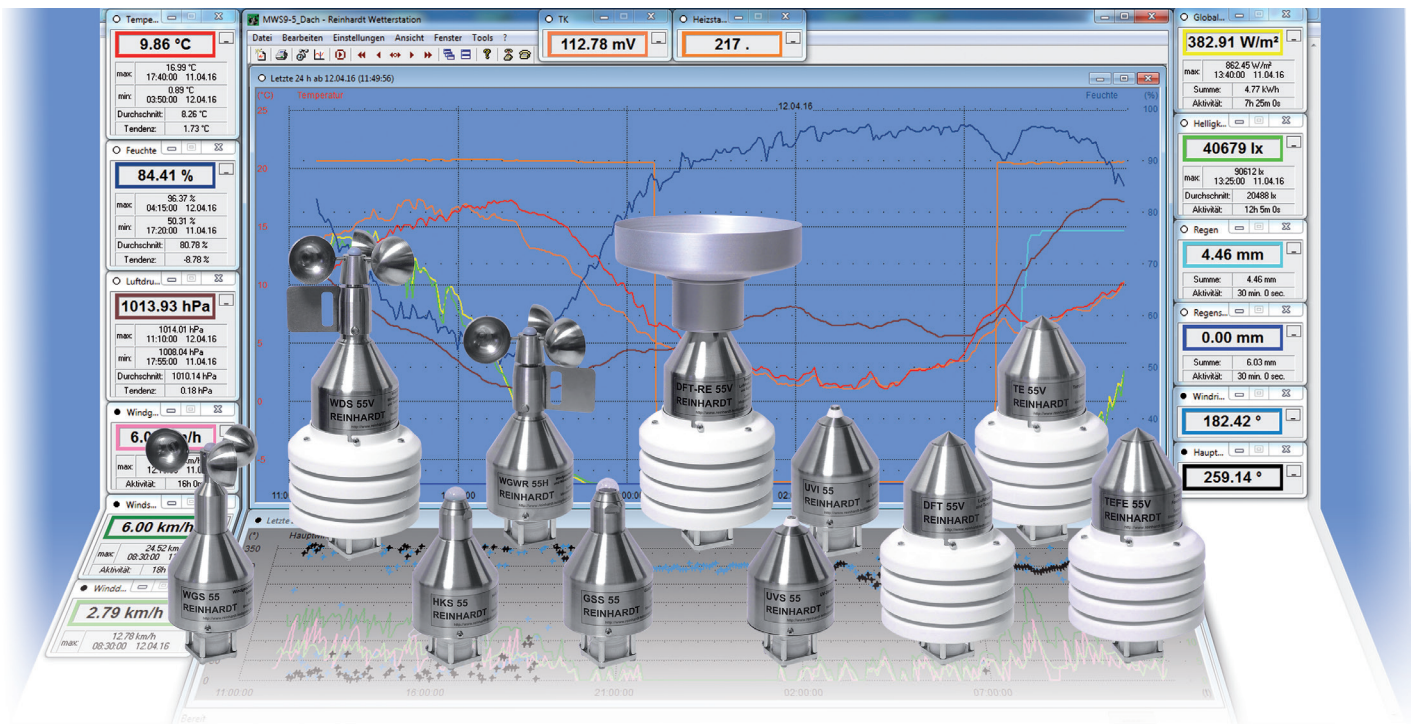

- High long-time stability
- Big internal data logger
- Evaluation electronics/interface in one housing
- Practice-oriented software
- Internal WEB-page (with PoE-option)
- Optional switching outputs
- Initial operation in 5 minutes without soldering etc.
- Stationary and portable, year-round operation
- Low current consumption
- High-quality steel grants durability
- Tested in in-circuit and function test
- Cycle end test in a climatic chamber
- Own hard- and software development
- Production and calibration at our site

The third generation of this series of weather and environment sensors developed and produced by REINHARDT excels in compactness and digital data transfer (RS232, RS422, RS485, USB, WLAN, GSM, TCP/IP).

#### Applications

Environmental measuring stations – acoustics – Formula1 Team courses – test courses of renowned tyre and car manufacturers – building management system – military – cable TV – power plants – airports – sports clubs – insurance companies – road maintenance depots – dump sites – petrochemical plants – food industries – market gardens – agriculture – schools and universities – research institutes – health resorts – tourist information

## Software

Even PC amateurs can work very quickly with the easy-to-use and practical menu-driven software. Software for WINDOWS 98® to WINDOWS 10® comes with the unit.

The measured values are displayed numerically and graphically with the standard evaluation and display software. The measured values come in a format that they can be read, processed and displayed with further software such as e.g. EXCEL®. The measured values can also be output as CSV-file (EXCEL®).

## Control Menu of the Software

In the special software menu you can set minimum or maximum limits for every measured parameter, logically link several sensors and control facilities in this way. When the limits are exceeded or come below, program steps will be executed which can activate an external relay board which e.g. controls greenhouses.

## Internal Data Logger

The weather and climate sensors come with big (8 GB) internal data logger. At a 10 s interval it stores data of more than 15 years. Store intervals from 1 s to 24 hours are allowed. The data can be read at any time so that portable use of the unit is possible. As there is a battery buffered clock, you can start storing the data even without a PC at any time.

## Configurable Website

With the PoE-option, a configurable internal website is available where the measured values can be displayed via browser.

## Switching Outputs

For control, two optional switching outputs (1 x contact, 1 x 5 VDC) can be switched dependent on the measured value. Up to 3 sensors can be logically linked.

## Data Format

The sensor identification is continuously transferred with the measured value. Thus integration of the weather and climate sensors into sophisticated equipment is easy. The measured values are linearised within the sensor and converted to an RS232-signal. Example for an ASCII-data string: 13:20:10,15.2.16,TE17.7,DR946.9,WR351.6,FE70.8,WG0.0,WS0.0,WD0.0,WC17.7,

## Heating

For undisturbed operation of the precipitation sensor and the wind sensors in winter a heating is recommended which is controlled dependent on temperature.

## Calibration

The electronics undergoes a burn-in of at least 1 week in a cycle between 0 °C and 50 °C. The sensor is calibrated in a climatic chamber between -25 °C to +55 °C. The generated reference values contribute to an interpolation table which is used for calibration of the devices. A comprehensive calibration instruction is available for calibrations in external laboratories (e.g. DAkkS-calibration).

## Expansions

The sensors which are largely made of high quality steel, can be expanded with additional sensors (by Plug + Play). High quality sockets are already fit for that. For sensor expansions (see last page) or further tasks there are free analog inputs (0 to 4.095 V) and optional digital inputs and switching outputs.

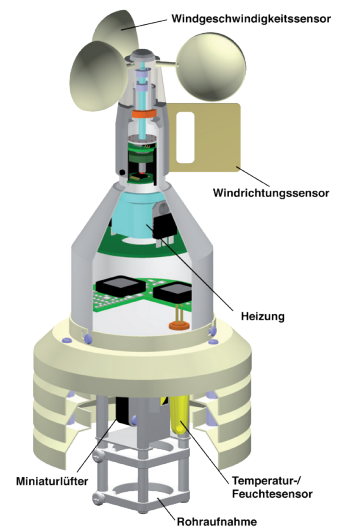

MWS 55 sectional drawing

A screenshot of a web browser displaying weather data for 'Reinhardt MWS'. The page has a yellow background and shows various weather parameters in a table format. The data is for '06. MÄRZ 2018 18:06:02'.

Reinhardt MWS					
06. MÄRZ 2018 18:06:02					
Temperatur:	Luftfeuchte:	Barometer:	Luftdruck:	Regenmenge:	
1.67 °C	85.26	991.44 hPa	919.22 hPa	0.00 mm	
Windgeschwindigkeit:	Windstärze:	Winddruckbehaft:	Windrichtung:	Hauptwindrichtung:	
0.00 km/h	0.00 km/h	0.00 km/h	285.64 °	---	
Temperatur:	Windstärke:	Globestrahlung:	Beleucht:	Wolkendeckungs:	
-0.49 °C	1.76 °C	47.12 W/m²	10055.00 lx		
Heizung:	Innentemperatur:	VCC:	Wolke:	Regenrate:	
0.00	10.78 °C	12.74	1.00	0.00 mm	

Website

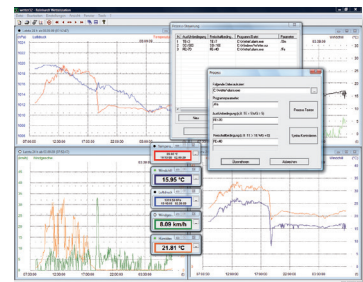

Control menu



Mobility package

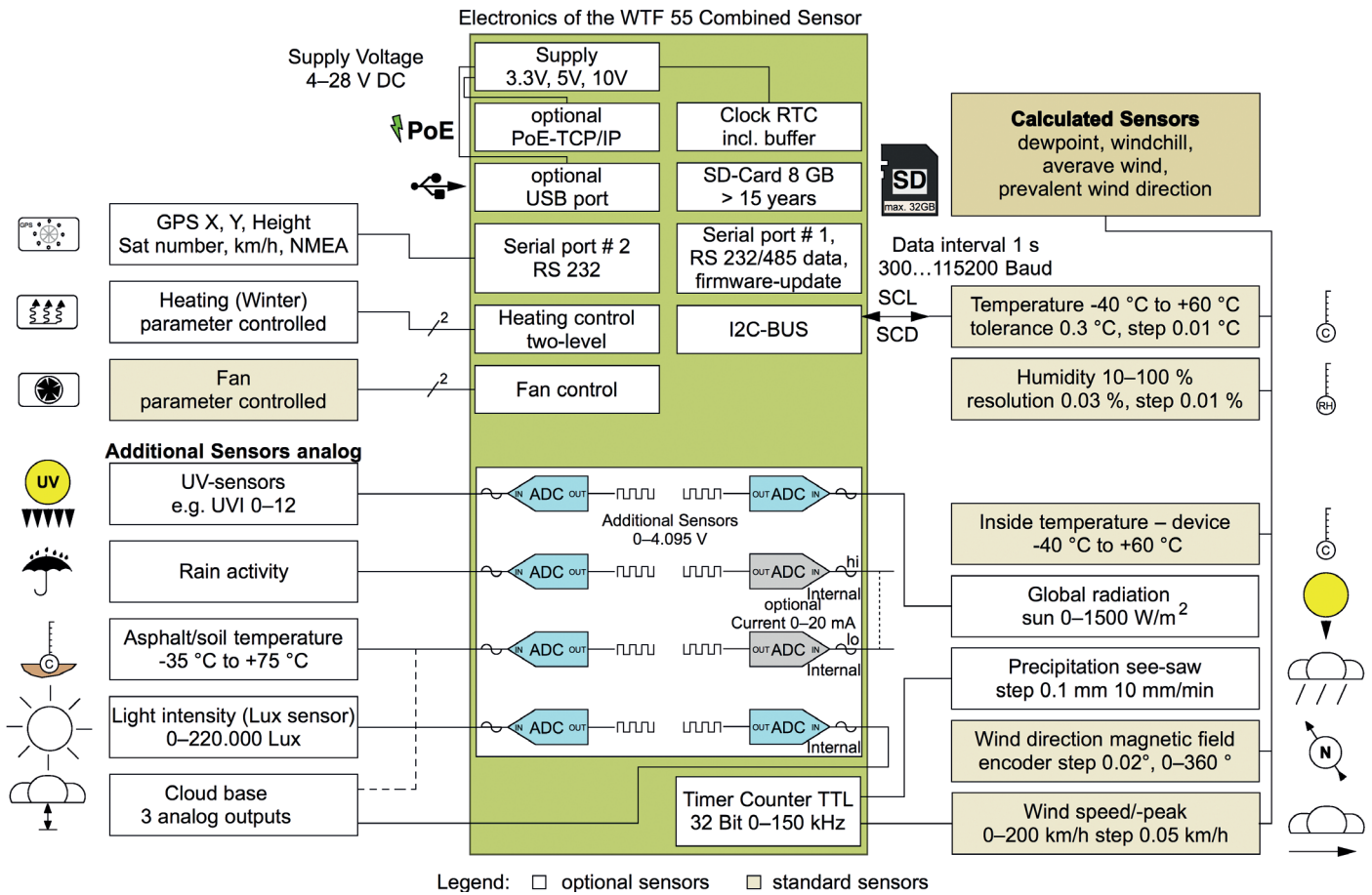

### WTF 55V Combined Sensor for Wind Direction, Wind Speed, Temperature and Humidity

**Wind direction, wind speed see Combined Sensor WDS 55V; temperature and relative humidity see Combined Sensor DFT 55V**

Baudrate: can be set between 300 and 115,200 baud  
 Current consumption 70 mA at 18 V  
 Dimensions: diameter 125 mm, height 295 mm  
 Weight: 1,600g  
 Heating: optional, 18 V, max. 1 A



### DFT 55V Combined Sensor for Barometric Pressure, Humidity, Temperature

**Temperature**

Measuring range: -40 to +60 °C, 0.01 ° resolution, accuracy 0.3 °

**Relative Humidity**

Measuring range: 10–100 %, 0.03 % resolution, accuracy ±2 %

**Barometric pressure (hose mounting for calibration at the bottom)**

Measuring range: 300 to 1,200 hPa absolute pressure, 0.01 hPa resolution

Accuracy: ±0.8 hPa (from 0–50 °C)

Baudrate: can be set between 300 and 115,200 baud

Current consumption: 70 mA at 18 V

Dimensions: diameter 125 mm, height 215 mm

Weight: 900g





### WDS 55V Combined Sensor for Wind Direction, Wind Speed and Temperature

Measuring parameter:	Wind direction, prevalent wind direction, wind peak, average wind, wind speed, windchill, temperature
Wind speed:	0 to 200 km/h, resolution 0.01 km/h, accuracy $\pm 2.5$ km/h
Wind direction:	0–360°, 0.025° resolution, accuracy $\pm 5^\circ$
Response:	0.8 m/s
Temperature:	-40 to +60°C, resolution 0.01°, accuracy 0.3°
Baudrate:	can be set between 300 and 115,200 baud
Current consumption	70 mA at 18 V
Dimensions:	diameter 125 mm, height 295 mm
Weight:	1,600 g
Heating:	optional, 18 V, max. 1 A



### DFT-RE 55V Combined Sensor for Barometric Pressure, Humidity, Temperature, Rain/Precipitation

Temperature, pressure, relative humidity see Combined Sensor DFT 55V

#### Rain/Precipitation

Maximum intensity:	10 mm/min, 0.1 mm resolution, accuracy 0.2 mm
Temperature range:	-40°C to +60°C with heating (optional) 0 to +60°C without heating
Baudrate:	can be set between 300 and 115,200 baud
Current consumption:	70 mA at 18 V
Dimensions:	diameter 165 mm, height 295 mm
Weight:	1,100 g
Heating:	optional, 18 V, max. 1 A

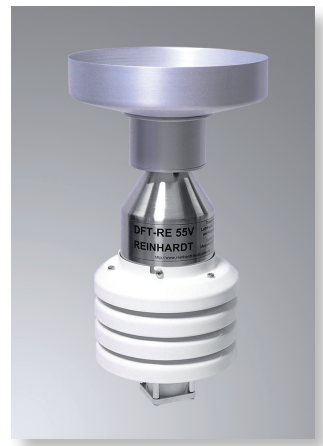

### TEFE 55V Combined Sensor for Temperature and Humidity

#### Temperature

Measuring range: -40 to +60°C, 0.01° resolution, accuracy 0.3°

#### Relative Humidity

Measuring range:	10–100%, 0.03% resolution, accuracy $\pm 2\%$
Baudrate:	can be set between 300 and 115,200 baud
Current consumption:	70 mA at 18 V
Dimensions:	diameter 125 mm, height 215 mm
Weight:	900 g



### WGWR 55 Wind Speed and Wind Direction Sensor

Measuring parameter:	Wind direction, prevalent wind direction, wind peak, average wind, wind speed
Wind speed:	0 to 200 km/h, resolution 0.01 km/h, accuracy $\pm 2.5$ km/h
Wind direction:	0–360°, 0.025° resolution, accuracy $\pm 5^\circ$
Response:	0.8 m/s
Application:	0–200 km/h
Baudrate:	can be set between 300 and 115,200 baud
Current consumption:	40 mA at 18 V
Dimensions:	120 mm diameter, height 215 mm
Weight:	775 g



### WGS 55 Wind Speed Sensor

Measuring parameter: Wind speed, wind direction, average wind  
Measuring range: 0–200 km/h, resolution 0.01 km/h  
Accuracy:  $\pm 2.5$  km/h  
Response: 0.8 m/s  
Baudrate: can be set between 300 and 115,200 baud  
Current consumption: 40 mA at 18 V  
Dimensions: 120 mm diameter, height 215 mm  
Weight: 775 g



### HKS 55 Lux Sensor

Measuring parameter: light intensity from 0–220,000 Lux (human eye response)  
Spectral range: 370 to 680 nm, 4 Lux resolution  
Temperature range:  $-40^{\circ}$  to  $+60^{\circ}$  C  
Baudrate: can be set between 300 and 115,200 baud  
Switching outputs: 1 x contact, 1 x 5 VDC; dependent on measured values; optional  
Current consumption: 40 mA at 18 V  
Dimensions: diameter 80 mm, height 170 mm  
Weight: 700 g



### GSS 55 Global Radiation Sensor

Measuring parameter: global radiation  
Measuring range:  $0-1,500$  W/m<sup>2</sup>, 0.3 W resolution,  $\pm 40$  W  
Spectral range: 0.3 to 2.8  $\mu$ m  
Temperature range:  $-40^{\circ}$  C to  $+60^{\circ}$  C  
Baudrate: can be set between 300 and 115,200 baud  
Switching outputs: 1 x contact, 1 x 5 VDC; dependent on measured values; optional  
Current consumption: 40 mA at 18 V  
Dimensions: diameter 80 mm, height 170 mm  
Weight: 700 g



### RMS 55V Rain/Precipitation Sensor

Measuring parameter: Precipitation/rain  
Max.intensity: 10 mm/min, 0.1 mm resolution  
Accuracy: 0.2 mm  
Temperature range :  $-40$  to  $+60^{\circ}$  C with or 0 to  $+60^{\circ}$  C without heating,  $0.1^{\circ}$  resolution  
Baudrate: can be set between 300 and 115,200 baud  
Current consumption: 40 mA at 18 V  
Heating optional: turned on automatically from  $5^{\circ}$  C  
Dimensions: diameter 165 mm, height 215 mm  
Weight: 800 g



# REINHARDT Weather and Environment Sensors

Technical Data of the Basic Sensors	Expansions of the Sensor Systems															
	USB or RS422 / RS485-Interface	WLAN	TCP/IP-Converter or PoE resp.	Rain/Precipitation Sensor with TTL-output	Add. Temp.-Sensor in a low rad. housing -40 to +60 °C (analog outp.)	Ground temperature sensor -40 to +75 °C (analog output)	Light inttens. sensor (Lux) analog	Global radiation sensor analog	Ultraviolet sensor analog	GPS-Mouse (Altitude/coordinates, Time – UTC)	GSM-Module	GSM-Remote inquiry	Cabling confectioned, 10m cable and PSU 18VDC, 1.33A	Software	Additional analog meas. inputs	Switching outp. (Contact, 5VDC)
<b>DFT 55V Combined Sensor Temp./Press./Humidity*</b> Temperature -40 to +60 °C resolution 0.01 °C tolerance 0.3 °C humidity 0% to 100% rel. F, resolution 0.03% tolerance 2%RF barometric/absolute pressure 300 to 1,200 hPa tolerance ±0.8 hPa, RS232-interface, internal data logger	○	○	○	○	○	○	○	○	○	○	○	○	●	●	5	○
<b>DFT-RE 55V Combined Sensor Temperature/Pressure/Humidity/Rain–Precipitation*</b> Temperature -40 to +60 °C resol. 0.01 °C, tol. 0.3 °C humidity 0–100% rel. F, resol. 0.03% tol. 2%RF barometr./absol. press. 300–1,200 hPa tol. ±0.8 hPa Precipitation: resol. 0.1 mm, accuracy 0.2 mm collecting area 200 cm <sup>2</sup> max. intensity: 10 mm/min; RS232-interface, internal data logger	○	○	○	○	○	○	○	○	○	○	○	○	●	●	5	○
<b>WDS 55V Combined Sensor Temperature/Wind Direction/Wind Speed</b> Temperature -40 to +60 °C resolution 0.01 °C tolerance 0.5 °C wind speed 0 to 200 km/h, response from 0.8 m/s, accuracy ±2.5 km/h, resol. 0.01 km/h Wind direction response <0.8 m/s, accuracy ±5° resolution: 0.025° measuring range 0–360°, RS232-interface, internal data logger	○	○	○	○	○	○	○	○	○	○	○	○	●	●	5	○
<b>WGWR 55V Combined Sensor Wind Speed/ Wind Direction</b> Wind speed 0 to 200 km/h, accuracy ±2.5 km/h, resolution: 0.01 km/h wind direction response <0.8 m/s, accuracy ±5° resolution: 0.025° measuring range 0–360°, RS232-interface, internal data logger	○	○	○	○	○	○	○	○	○	○	○	○	○	●	5	○
<b>WGS 55V Wind Speed Sensor *</b> Response from 0.8 m/s, accuracy ±2.5 km/h, resol.: 0.01 km/h, RS232-interface, internal data logger	○	○	○	○	○	○	○	○	○	○	○	○	○	●	5	○
<b>GSS 55 Global Radiation Sensor *</b> 0 to 1,500 W/m <sup>2</sup> , resolution 0.3W accuracy ±40W Spectral range, 0.3 to 2.8 μm RS232-interface, internal data logger	○	○	○	○	○	○	○	-	○	○	○	○	○	●	5	○
<b>RMS 55 Rain/Precipitation Sensor</b> Resolution: 0.1 mm, accuracy 0.2 mm collecting area 200 cm <sup>2</sup> max. intensity: 10 mm/min RS232-interface internal data logger	○	○	○	○	○	○	○	○	○	○	○	○	○	●	5	○
<b>Heating* for Precipitation Sensor 18V, max. 1A</b> with supply, 10m cable and temperature control	-	-	-	○	-	-	-	-	-	-	-	-	-	-	-	-
<b>HKS 55 Light Intensity Sensor * (Lux-Sensor)</b> 0 to 220,000 Lux, resolution 4 Lux, tolerance ±6% RS232-interface, internal data logger	○	○	○	○	○	○	-	○	○	○	○	○	○	●	5	○
<b>UVS 55 Ultraviolet Radiation *</b> 0 mW to 15,000 mW, resolution 1 mW, tolerance ±10%, spectral range 320 nm–395 nm RS232-interface, internal data logger	○	○	○	○	○	○	○	-	○	○	○	○	○	●	5	○

\* Not together with solar supply

Legend: ● = Series ○ = Option – = not possible

IE & OE – Specifications subject to change without notice! 04/2018