

# Manual

## MWS 3 & 485-Sensors

with Microprocessor  
without datalogger



**REINHARDT System- und  
Messelectronic GmbH**

Bergstr. 33, D-86911 Dießen-Obermühlhausen  
Tel. 0049 - 8196 - 934100 or 7001

E-Mail: [wetter@reinhardt-testsystem.de](mailto:wetter@reinhardt-testsystem.de)  
[www.reinhardt-wetterstationen.de](http://www.reinhardt-wetterstationen.de)

# Table of contents

<b>1 Caution</b> .....	<b>5</b>
1.1 Intended Use.....	5
1.1.1 Storage.....	5
1.2 Safety Regulations.....	5
1.3 Mounting.....	6
<b>2 Setting Up the Weather Station</b> .....	<b>6</b>
2.1 Installation of Hardware.....	6
2.2 Software Installation.....	7
2.3 Starting the Software.....	7
<b>3 Technical details</b> .....	<b>7</b>
3.1 Maintenance.....	7
3.2 The sensors.....	8
3.2.1 The Temperature sensor (MWS 3, DFT 485, FTS 485 and DTS 485).....	8
3.2.2 The Humidity sensor (MWS 3, DFT 485 and FTS 485).....	8
3.2.3 The Pressure sensor (MWS 3, DFT 485 and DTS 485).....	8
3.2.4 The Wind Speed sensor (MWS3, WGS 485, WGWR 485).....	9
3.2.5 The Wind Direction sensor (MWS3, WRS 485, WGWR 485).....	9
3.2.6 The Clouds sensor WKS 485.....	9
3.2.7 The light intensity sensor HKS 485.....	10
3.2.8 The Global radiation sensor GSS 485.....	10
3.2.9 The Ultraviolet-radiation sensor UVS 485.....	11
3.2.10 The UVI-radiation sensor UVIS 485.....	11
3.2.11 Der RainDetectionRadar sensor RDR-485.....	12
3.2.12 Sensitivity setting of the RDR-485.....	12
3.3 Sensor Accuracy.....	13
3.3.1 Measuring Ranges.....	13
3.4 Power Supply.....	14
3.4.1 Current consumption.....	14
3.4.2 Power consumption.....	14
3.5 Data Format.....	15
3.5.1 RS232 / RS422 port.....	15
3.5.2 RS485 port.....	16
3.6 System requirements.....	16
3.6.1 System requirements (32bit-Versions).....	16

# Manual MWS 3 & 485-Sensors

<b>4 Connections and Pin assignments</b> .....	<b>17</b>
4.1 Cables .....	17
4.1.1 Data Cable - Allocation of the Connection Cable for MWS 3 .....	17
4.1.2 Allocation of the Connection Cable for Sensors with RS422-port.....	18
<b>5 Excerpts from the Directions of DWD for Automatic Weather Stations</b> .....	<b>19</b>
<b>6 Trouble Shooting</b> .....	<b>20</b>
6.1 Fault Protocol File (16 bit versions).....	20
6.2 Protocol-files (32 bit versions).....	20
6.2.1 Log-file in case of error (ErrLog.txt) .....	20
6.2.2 Logfile when starting up (log.dat) .....	20
<b>7 Options</b> .....	<b>21</b>
7.1 Available displays.....	21
7.2.1 Meteograph .....	21
7.2.2 DKA1 .....	21
7.2.3 DMMK .....	21
<b>8 Technical Appendix</b> .....	<b>22</b>
8.1 Controlling the Microcontroller.....	22
8.1.1 Input parameters of MWS 3 / 485-Sensors -Microcontroller .....	22
8.2.2 Querying the Microprocessor .....	25
8.2.3 Order of the MWS 3 sensors.....	26
<b>9 Exchange Connectors</b> .....	<b>27</b>

# Manual MWS 3 & 485-Sensors



MWS 3



DFT 485  
FTS 485  
DTS 485



WKS 485



UVS 485  
UVIS 485



GSS 485



WGWR 485



WGS 485



HKS 485



RDR 485

## 1 Caution

### 1.1 Intended Use

The REINHARDT-Weather station MWS 3 & the 485-Sensors (in the rest of the manual always named as MWS3) are designed for stationary operation for short time measurements to collect climatic parameters outside. The unit must not be operated on vehicles or machines due to the vibrations! For long time measurements year-round REINHARDT offers optionally heated weather stations with data logger, for example: [MWS 5MV](#), [MWS 9-5](#) and sensors with data logger, like [WDS 1MV](#), [DFT 1MV](#), ...

The operating temperature range is from -40°C ... +60°C.

Any use other than described above may cause damage of the product or lead to other dangers.

Do not mount the weather station in reach of children and pets.

Carefully read the complete operating manual. It contains important information about the installation and operation.

#### 1.1.1 Storage



**CAUTION:** If the MWS 55 is not put into operation immediately after receipt, it must be stored in a well ventilated place! The MWS 55 must not be stored in a package for a longer time for all packing materials are emitting solvents which leads to drift of the humidity sensor and the humidity measurement drifts out of specification!!

See: [Sensirion Humidity Sensors Handling Instructions.pdf](#) or here:

[https://sensirion.com/resource/user\\_guide/sht/handling\\_instructions](https://sensirion.com/resource/user_guide/sht/handling_instructions)

### 1.2 Safety Regulations

The instruments are manufactured according to modern technical standards and can be operated without danger when used as directed.



Damage caused by non-observance of this operating manual can lead to forfeiture of warranty. We shall not assume any liability for subsequent damage.

We shall not assume any liability for damage of items or persons caused by improper handling or non-observance of the safety instructions! In such cases any guarantee claims shall become null and void.



Dear customer, the following safety and hazard notices not only serve the protection of your health but also the protection of the appliance. Please read the following points carefully.



The supply voltage is converted by isolated transformers into voltages of maximum 24VDC (the MWS3 can be operated at voltages up to 30VDC).

Please do only use the supplied power supply units.



The weather station includes pointed and sharp-edged parts (i.e. windvane and edges of the sensor's housing), which may cause injuries when handled without care.



Do not leave the packaging material lying around. These parts are dangerous toys in the hands of children.



Handle the product with care. Blows or impact, or dropping it even from a small height will damage it.



## 1.3 Mounting

For mounting the weather station a sensor holder (a stable plate with a 18mm hole) is needed. This holder may be a folded sheet mounted at a pipe or a cantilever of a mast. The threaded fitting of the MWS 3 is stuck into the 18mm hole, the MWS 3 then orientated to north and then fixed well with the attached nut.



**CAUTION: Never hold the sensor at the top when tightening the sensor but only at the bottom. Otherways the internal board may be bent and destroyed!**

Finally the cable has to be connected and the power supply plugged into the mains. The MWS 3 now is ready for operation and sends a data string each second (RS232 /RS422 only).

The MWS 3 and the 485 Sensors contain sensors for measuring the most important climatic parameters like temperature, humidity, air pressure, wind speed and wind direction. All parameters can be displayed with the [32bit-software \(as an option\)](#) as graphical chart, as digital display or in a multiple display. Furthermore statistical values, a process control unit and a history is available.

## 2 Setting Up the Weather Station

### 2.1 Installation of Hardware

Mount the weather station as described above. Take care that the MWS 3 is mounted as perpendicularly as possible, otherwise the windvane will not work properly and will preferably rotate in one direction.



The weather station must be set up at a place which is exposed to wind, because otherwise wind direction and wind speed cannot be measured correctly. (Please see "Directions of DWD").

If you haven't ordered a ready made cable, you need to build a cable with the attached connectors by yourself. For power supply you need a voltage between 6 an 30VDC and at least 20mA.

Connect the cable as follows:

Connect the 9pole connector to a free serial interface of your PC (COM1, COM2, ...)

Plug in the power supply into a power outlet 230V/50Hz or connect a solar panel with accumulator.

#### Note on Security

*Please note that the nominal value of the PSU must be between 6 V and 30 V DC voltage. Please note also that all the power supplies we provide are only made for use in dry rooms.*

*The MWS 3 doesn't have a reverse pole protection so please pay attention to proper connection of the power supply!*

*Never loosen the 6 allen screws holding the complete housing. Please note that in case of non-compliance the MWS 3 may be damaged!*

After installing the hardware, the software is installed and started.

## 2.2 Software Installation

Insert the WeatherCD into your CD-drive. Please note that the [32bit-software](#) is an option with some single sensors!

You need an HTML-capable browser (Firefox, Internet-Explorer or else).

If Autostart is activated, the CD starts on its own, if not, you execute STARTER.EXE in the CD root directory. (If you want to install the software packages directly, you will find the paths for the single installations in the install.html file.)

Now you follow the instructions of the WeatherCD.

## 2.3 Starting the Software

Start the software by double-clicking the program icon.

First choose the directory for storing the weather data and as an option, a second path for the weather data. Insert your desired storage interval.

Then select ***Without datalogger*** under ***Configure data storage***.

A new dialog opens.

Select the interface (COM1, COM2, ...).

If the software doesn't start up, a damaged weather data file on the harddisk or not enough free memory may be the reason. This may lead to termination of the software.

For more detailed information refer to the latest software manual [here](#).

If you want to use own software you may read the data string directly from the COM port.

The COM port can be disabled so that you can request a data string when ever you want. When using RS485, then this is the basically operation.

More details you'll find under chapter 8 (technical appendix)

## 3 Technical details

For the MWS 3 hasn't got a data logger the software needs to run permanently to get gapless weather data!

### 3.1 Maintenance

Because of its elaborated sensors, the MWS 3 needs no maintenance.



*Our warranty ends if there is any intervention into hardware or software from your side.*

MWS 3 weather station has been developed for stationary use for short time measurements under normal climatic conditions (temperate zone). Use under extreme conditions such as e.g. on board of a ship, mobile use on a measuring vehicle etc. has not been tested. It is therefore not recommended to set up the weather station where it is exposed to salt or salt water ( e.g. right at the coast etc.).

It can be used on a measuring car under certain conditions although the measured values of the wind sensors cannot be reproduced. Operation on a vehicle off road is not recommended due to strong vibrations and strong shocks!

## 3.2 The sensors

### 3.2.1 The Temperature sensor (MWS 3, DFT 485, FTS 485 and DTS 485)

Temperature measurement is based on a fully calibrated sensor element with I<sup>2</sup>C interface. The measured value is processed by the microcontroller and then output at the serial port with the identifier TE. The temperature sensor is placed inside the MWS 3 housing.

Range: from -40 °C to + 60 °C, measuring accuracy ± 1.0 °C, (display also possible in Kelvin or °Fahrenheit)

**CAUTION: Compared to temperature measurements in big shielded cabins the measured values can be higher when the sun is shining. If the temperature measurements must correlate with the measurements in big shielded cabins you should measure temperature in the shadow or measure with an additional temperature sensor placed in the shadow or in a big shielded cabin!**

Unit [°C]

### 3.2.2 The Humidity sensor (MWS 3, DFT 485 and FTS 485)

is based on a fully calibrated sensor element with I<sup>2</sup>C interface. The measured value is processed by the microcontroller and then output at the serial port with the identifier FE. The humidity sensor is placed inside the MWS 3 housing.

The humidity sensor can be used in a temperature range between -40 °C to + 60 °C. It is linearized to an accuracy of 2.5 % between 10% and 90% relative humidity at 25°C.

Range: from 10 to 100 %, measuring accuracy ±2.5 % (between 10% and 90% relative humidity), display also as dewpoint measurement in °C or °F

Unit [%]

#### NOTE

*This sensor is very responsive to static charge and air pollution (dust, aggressive gases, but also salt). Please note that under unfavourable conditions (i.e. microbic stress caused by moulds, bacteria) this sensor ages faster than under normal conditions.*

### 3.2.3 The Pressure sensor (MWS 3, DFT 485 and DTS 485)

is a 16-bit pressure module with integrated temperature sensor for compensation. The pressure sensor also has got an I<sup>2</sup>C interface. Its value has got the identifier DR on the serial port.

The temperature sensor of the pressure sensor has got the identifier TD on the serial port.

**The sensor TD is essential for compensating the pressure sensor and must not be disabled!**

The pressure sensor can be used in the temperature range of -40 °C to + 60 °C.

Measuring range: from 300 hPa to 1100 hPa with ± 1.0 hPa accuracy typical;

display can be reduced to 0 m above sea level (input of the local altitude in [m], display also in mm mercury column or Inch mercury column).

The formula for reducing pressure to sea level used in this sensor is:

Barometer = absolute pressure [hPa] + ((altitude [m] + 199,1) / 10,079) - ((altitude [m] - 2000) / 450)<sup>2</sup>

This is a simple formula for reducing pressure. There are other formulas for reducing pressure to sea level. You'll find in the web. You may add one of these formulas into the Reinhardt weather software to reduce pressure with a more complex formula.

Unit [hPa]

This sensor can be transported by air cargo!



## 3.2.4 The Wind Speed sensor (MWS3, WGS 485, WGWR 485)

is made up of an anemometer with optical scanning. Wind speed is measured without touch using an optical detector. A peak detector finds every wind peak and hands them on the measuring software. An average value is determined within the respective memory intervals and is reset each time the software stores onto the harddisk. The sensor identifiers are WG for wind speed, WS for wind peak and WD for wind average.

Range: in km/h from 0 to 200 km/h with  $\pm 2.5$  km/h measuring accuracy, (display also in m/s, miles/h, Knot or Beaufort), starting speed  $< 0.8$  m/s.

As we have a very comfortable, 3-fold way of measuring wind speed with current wind speed (WG), average wind speed (WD) and wind peaks (WS), you can conform your wind measurement to your very needs.

Please note that dependent on the current winds, the 3 different methods of measuring wind speed can result in very differing graphs: When measuring WG, only a current value is written in the selected measuring interval, when measuring WD and WS, there is continuous evaluation and the whole measuring period is monitored.

Unit [km/h]

## 3.2.5 The Wind Direction sensor (MWS3, WRS 485, WGWR 485)

There is a weather vane with a precision magnetical encoder and a rotation angle of  $360^\circ$  for measuring wind direction. Wind direction is given in  $^\circ$ , with  $90^\circ$  being East,  $180^\circ$  being South,  $270^\circ$  being West and  $0^\circ$  being North.

Range: in  $360^\circ$ , measuring accuracy  $5^\circ$ , starting speed,  $< 0.8$  m/s, hysteresis  $< 5^\circ$ .

Output is performed as WR (winddirection).

Unit [ $^\circ$ ]

## 3.2.6 The Clouds sensor WKS 485

The Cloudsensor detects if there are clouds or not using a thermopile.

If the sensor detects clouds in it's field of view, the sensor with the identifier WK has got the value 1, if the sensor detects no clouds, this value is 0.

An additional internal signal is used to calculate the cloud's base using a special formula.

This formula calculates the cloud's base as follows:  $T(h) = T_0 - h * y$ , where  $T(h)$  is the cloud's temperature,  $T_0$  is the ambient temperature of the sensor,  $h$  is the altitude and  $y$  is the temperature gradient in [K/m].

The temperature gradient  $y$  is the cooling down in [K] per metre altitude. The value of this gradient is depending on the humidity of the air (dry adiabatic lapse rate or wet-adiabatic lapse rate). The wet-adiabatic lapse rate is app.  $5 * 10^{-3} \text{ Km}^{-1}$ , the dry adiabatic lapse rate is app.  $10^{-2} \text{ Km}^{-1}$ .

For the exact weather conditions in the atmosphere are mostly not known, meteorologists calculate with an average value of  $6.5 * 10^{-3} \text{ Km}^{-1}$ , this means a cooling down of app.  $6.5^\circ\text{C}$  per kilometer. This value also is used calculating the cloud's base within the WKS 485.

Finally the sensor with the identifier WU contains the cloud's base in [m].

The calculation of the cloud base by this formula can be faulty due to influences caused by different weather situations and must not be used for security-related measurements, (i.e. air traffic, ...)!

## 3.2.7 The light intensity sensor HKS 485

The light intensity sensor contains a photodiode array, an integrating analog-to-digital converter (ADC), signal processing circuitry, lux calculation logic, and an I<sup>2</sup>C serial interface on a single CMOS integrated circuit to provide lux data with a 16-bit output.

It measures the light intensity in lux within the visible spectrum (Human Eye Response).

The measuring range is 0..220000 lux, the sensor identifier is LX.

The accuracy is +/- 10% of the measured value.

The spectral response and the angular displacement of the sensor you can see below:

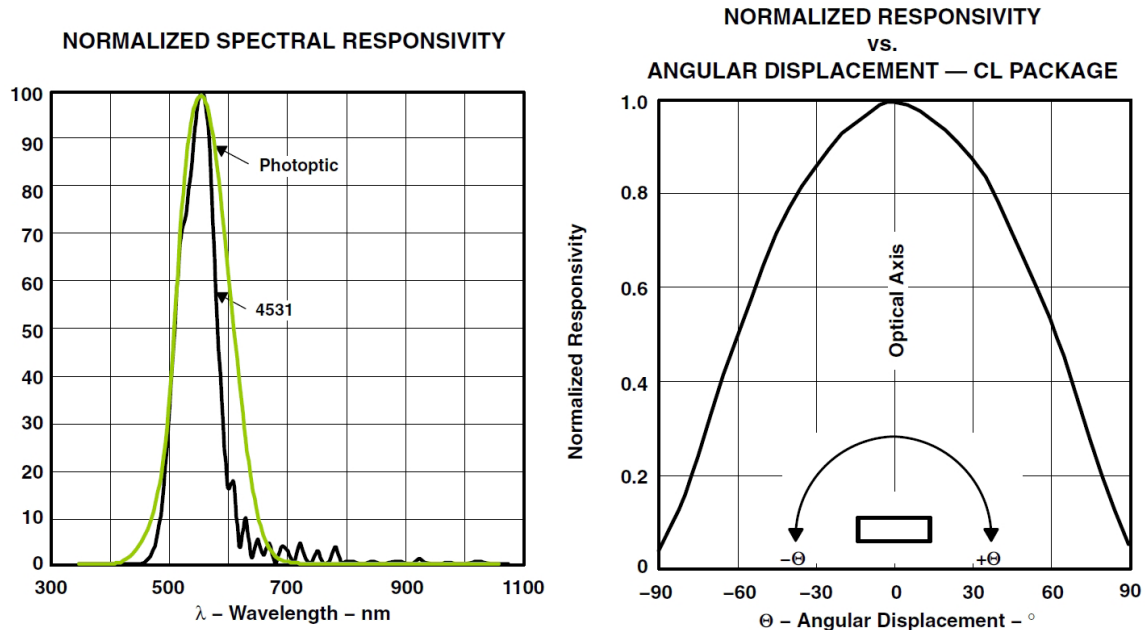

## 3.2.8 The Global radiation sensor GSS 485

This is a pyranometer which absorbs radiation between 305 and 2800 nm. The temperature of a black and a reflecting element is subtracted and linearised by the software. The measuring sensor is a thermocouple.

The values are edited in W/m<sup>2</sup>.

Two identifiers are output in the data string:

SO is the global radiation in W/m<sup>2</sup>,

SI is also the global radiation in W/m<sup>2</sup>, but strongly attenuated and with lower resolution.

The measured value reaches 90 % of its final value after about 60 seconds.

Unit [W/m<sup>2</sup>]

Range: from 0 to 1300 W/m<sup>2</sup> with ±40 W/m<sup>2</sup> accuracy.

## 3.2.9 The Ultraviolet-radiation sensor UVS 485

measures ultraviolet radiation in UV-A spectrum in  $\text{mW}/\text{m}^2$ . The spectral range is 320nm..395nm with maximum sensitivity at 330nm.

The spectral response of the sensor is displayed below. It is the curve for the JEC 0.1A!

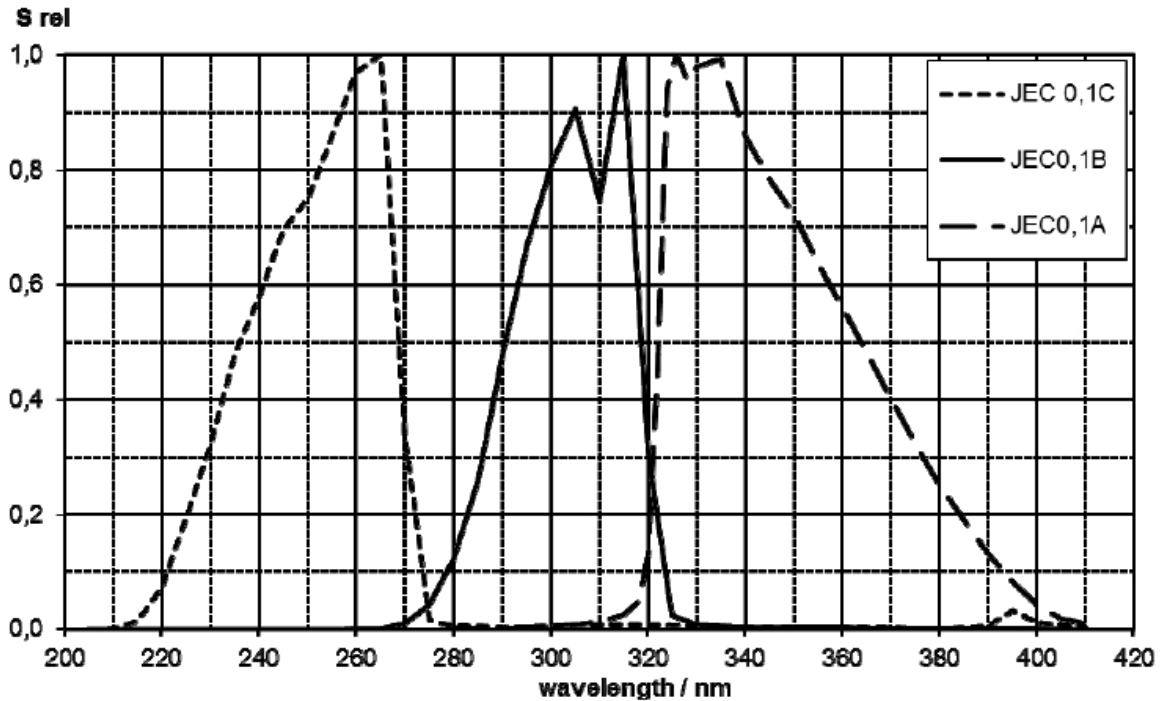

## 3.2.10 The UVI-radiation sensor UVIS 485

directly measures the UV-Index (erytymal action spectrum) with the maximum at 297nm. The measuring range is between 0 and 12 UVI.

The spectral response of the sensor is displayed below.

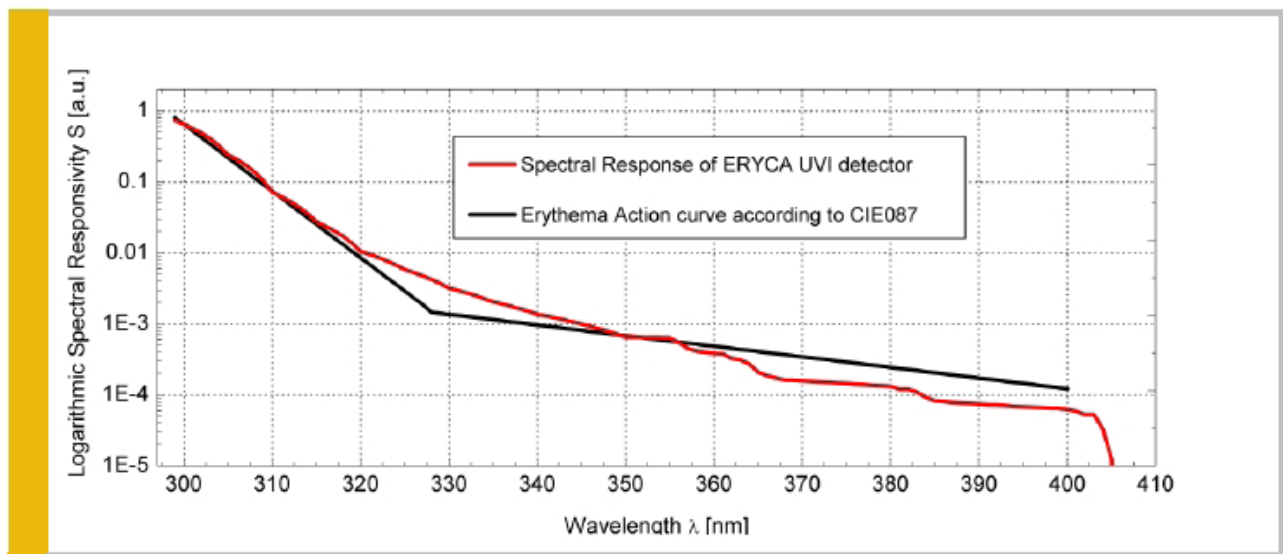

## 3.2.11 Der RainDetectionRadar sensor RDR-485

is a maintenance free detector using a 24GHz Doppler-Radar for detecting rain and hail.

To avoid errors in detecting the sensor must have free sight at the top.

Caution: very light drizzle and snow cannot be detected reliable. This is caused by too small content of water, droplet size and drop speed reflecting the radar signal not sufficient enough.

The RDR-485 detects direct and passing drops. The clear distinction between raindrops and other objects causing a similar radar reflection is difficult. So the RDR-485 must be mounted distantly enough to moving objects like trees, streets, persons i.e.

The sensor also must not be mounted near neon tubes, HID-lamps and other systems using 24GHz frequency.

To avoid detection in error caused by a single event (spurious pulse, insects, birds or contaminants carried by the air) the first pulse is blocked for app. 1.5 seconds. After this time the detection is enabled for app. 1 minute and sets the sensor RA to high when another detection happens within this time.

After being set to high the sensor RA stays high for app. 2 minutes. When a new detection is performed within these 2 minutes this countdown is restarted (retriggered).

## 3.2.12 Sensitivity setting of the RDR-485

The RDR-485 sensor has got a second sensor RS in it's output string which tells the detection intensity. This value has got the unit [mV].

The sensitivity can be set in 2 levels. The command !X0 sets the sensor from sensitive to insensitive (detection is triggered at app. 120mV). !X1 = sets the sensor to sensitive (detection is triggered at app. 70mV).

When using the RDR-485 in proper environment (not near interference sources) the setting should be left at sensitive (!X1) to ensure that the sensor detects even small rain drops.

The setting is set to sensitive by default.

## 3.3 Sensor Accuracy

Temperature:	± 0.5 °C (at +25°C) ± 1.0 °C (between -10°C and +60°C)
Humidity:	± 2.5 % (between 10% and 90% relative humidity at 25°C) ± 4.0 % (between 10% and 90% relative humidity, from 0..50°C) ± 5.0 % (between 10% and 90% relative humidity, from -30..0°C)
Pressure:	± 1.0 hPa (typical between 300..1100 hPa at 0°C..50°C) ± 2.5 hPa (max. between 700 hPa and 1100 hPa at 0°C..50°C) ± 3.0 hPa (max. between 300 hPa and 700 hPa at 0°C..50°C) ± 4.0 hPa (max. between 300 hPa and 1100 hPa at -20°C..0°C)
Temperature pressure sensor:	± 2.0 °C (between -10°C and +60°C)
Wind direction:	± 5° (at 5°C..50°C), hysteresis < 5°
Start speed:	< 0.8m/s (at 5°C..50°C)
Wind speed:	± 2.5 km/h (at 5°C..50°C)
Start speed:	< 0.8 m/s (at 5°C..50°C)
Light intensity:	+/- 10% maximum drift of -0.25% / °C from -15°C..0°C maximum drift of -0.20% / °C from 0°C..70°C
Global radiation:	+/- 40W/m <sup>2</sup>
UV-A:	+/-10%
UVI:	+/-1/2 UVI

### 3.3.1 Measuring Ranges

Temperature:	from -40 ° to + 60 °, resolution 0.01°C (16bit)
Relative humidity:f	from 10 to 100 % resolution 0.01 % (16 bit)
Dewpoint:	from -40 ° to + 60 °, resolution 0.01°C
Absolute pressure:	from 300 hPa to 1100hPa in 0.03 hPa resolution (16 bit)
Wind direction:	0 to 360 °, resolution 0.3 ° (10 bit)
Wind speed:	in km/h from 0 to 200 km/h with 0.05 km/h resolution
Light intensity:	in lux from 0 to 220000 lux with resolution of 4 lux
UV-A:	0 to 50000 mW/m <sup>2</sup>
Global radiation:	0 to 1500 W/m <sup>2</sup>

Measures MWS 3:

Size:	Outer diameter 110 mm at a height of 180 mm
Weight:	app. 350 g

## 3.4 Power Supply

6-30 VDC, 8-30V (RDR-485)

### 3.4.1 Current consumption

Typical current consumption of MWS 3 with RS-232 at different voltages:

Input voltage:	6V	12V	18V	24V
MWS 3:	19mA	9.7mA	6.8mA	5.2mA
DFT 485:	2.4mA	1.3mA	0.9mA	0.7mA
WGS 485:	7.0mA	3.9mA	3.2mA	2.8mA
WKS 485:	3.2mA	1.6mA	1.1mA	0.9mA
GSS 485 :	5.7mA	2.8mA	1.9mA	1.5mA
HKS 485:	4.5mA	2.3mA	1.6mA	1.2mA
UVIS 485:	5.6mA	2.9mA	2.0mA	1.6mA
RDR 485:	38mA (8V)	25mA	18mA	15mA

### 3.4.2 Power consumption

The typical power consumption with RS-232 at 18VDC is:

MWS 3	: 6.8mA, power consumption: 122mW
DFT 485	: 800µA, power consumption: 16mW
WGS 485	: 3.2mA, power consumption: 58mW
WKS 485	: 1.1mA, power consumption: 20mW
GSS 485	; 1.9mA, power consumption: 34mW
HKS 485	; 1.6mA, power consumption: 29mW
UVIS 485	; 2.0mA, power consumption: 36mW
RDR 485	; 18mA, power consumption: 324mW



## 3.5 Data Format

### 3.5.1 RS232 / RS422 port

The data format of the transmitted data looks like this:

Example of a datastring :

TD22.13, TE22.09, DR952.25, WG2.00, WR78.91, FE35.58, WS4.11, WD3.29

Every second MWS 3 transmits a data record which includes the measured values separated by comma, the single measured values with sensor identification come in the following order:

Temperature of pressure sensor (TD), temperature (TE), barometer (DR), wind speed (WG), wind direction (WR), humidity (FE), wind peak (WS) and average wind (WD).

The datastring ends with <CR><LF>.

The data format of DFT 485 looks like this.

Example of a datastring :

TD22.13, TE22.09, DR952.25, FE35.58

Every second the DFT 485 transmits a data record, which includes the measured values separated by comma, the single measured values with sensor identification come in the following order:

Temperature of pressure sensor (TD), temperature (TE), barometer (DR) and humidity (FE).

The datastring ends with <CR><LF>.

The data format of WGS 485 looks like this.

Example of a datastring :

WG9.13, WS18.23, WD12.23,

Every second the WGS 485 transmits a data record, which includes the measured values separated by comma, the single measured values with sensor identification come in the following order: Current wind speed (WG), windpeak since the last reset (WS), average wind speed since the last reset (WD).

The datastring ends with <CR><LF>.

The data format of WKS 485 looks like this.

Example of a datastring:

WU1264.00, WK1.00,

Every second the WKS 485 transmits a data record, which includes the measured values separated by comma, the single measured values with sensor identification come in the following order: Calculated cloud's base in [m] (WU), cloudy = 1.00, no clouds = 0.00 (WK),

If the calculated cloud's base exceeds 4000m, the sensor switches to "no clouds".

This threshold may be changed by using a terminal software.

For questions how to perform, please contact us.

The datastring ends with <CR><LF>.

The data format of HKS 485 looks like this.

Example of a datastring:

LX23824.00

Every second the WKS 485 transmits a data record, which includes the light intensity in [lux].

The datastring ends with <CR><LF>.

The order of the sensors can be changed by reconfiguring the output positions (!Kxx) with internal sensor numbers. (see technical appendix - chapter 8)

By default, the data are transmitted with 9600BAUD, 8bit, no parity and a stopbit. (For evaluation with your own software, you can set several output modi - see technical appendix - chapter 8)

On harddisk, a data file is created every month with a format which is similar to that of the transmitted data. The data files receive the extension .MWS

Example : The file of January 2011 is named 01\_11.MWS when using 16-bit versions of the software and 01\_2011.MWS with 32-bit software.

In case of missing data (caused by power fail, i.e.) the software writes data with measuring values of -99999 to ensure integrity of the time axis. The software construes these values (-99999 and -99997) as missing data and creates measurement gaps in the graphical displays.



## **CAUTION!**

**In RS422 mode the EEPROM is write protected due to safety reasons to avoid accidentally setting the sensor to RS232 mode what would lead to malfunction of the sensor and the need to open and repair it!**

**The write protection can be removed in the SECURE mode of the sensor.**

(See 8.1.1 - Input parameters of MWS 3 / 485-Sensors -Microcontroller)

## **3.5.2 RS485 port**

The format of the data is the same as described above with RS 232 / RS422.

But note that with RS485 the sensor always is tristate and only sends any data when data are requested with the sensor's address.

If the sensor has got the address "10", the command for requesting the current data string is: ?10U, followed by Carriage Return and Line Feed (Press the ENTER key)

## ***Important!!***

***The standard Reinhard software is not able to read sensor's data with RS485 port. You'll need an own software application to perform!***



## **CAUTION!**

**In RS485 mode the EEPROM is also write protected due to safety reasons to avoid accidentally setting the sensor to RS232 mode what would lead to malfunction of the sensor and the need to open it!**

**The write protection can be removed in the SECURE mode of the sensor.**

Since version 1.29 a delay after receiving a command can be set for the sensor.

The command is !SWx, where x is a delay from 1..255 milli seconds.

(See 8.1.1 - Input parameters of MWS 3 / 485-Sensors -Microcontroller)

## **3.6 System requirements**

### **3.6.1 System requirements (32bit-Versions)**

At least a computer mit Pentium1 / 200 processor and 32MB RAM.

Runs with WIN98 SE, WIN ME, WIN 2k, WIN XP, Vista and WINDOWS 7.

Using the F1-key or the "?" in the menu bar, you can call the Online-Help at any time.

## 4 Connections and Pin assignments

### 4.1 Cables

#### 4.1.1 Data Cable - Allocation of the Connection Cable for MWS 3

7 pole connector (MWS 3 connection)		9-pole interface connector
Pin 1 (GND)	←————→	Pin 5 (GND)
Pin 2 (GND - used for MWS 9-5)		
Pin 3 (RXD-MWS 3)	←————→	Pin 3 (TXD-PC)
Pin 4 (TXD-MWS 3)	←————→	Pin 2 (RXD-PC)
Pin 5 (VCC 18VDC)		
Pin 6 (R- with RS422 /485)		
Pin 7 (T- with RS422 /485)		

Connect Pin 4 and 6  
Connect Pin 7 and 8

The data cable can be lengthened to up to 50 m. under optimum conditions and with suited cable (not in industrial environment!!)

In case you lengthen the data cable, please take care that the connections in the connector at the computer must be wired.

(Connect Pin 4 to Pin6 and Pin7 to Pin8).

#### Datenkabel MWS Standard RS232 V2.0 Data Cable MWS Standard RS232 V2.0

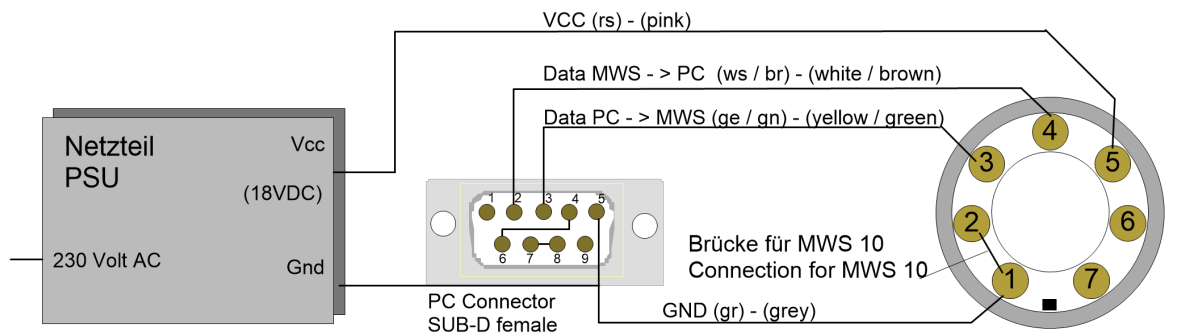

Kabellänge - cable length : max 100 m  
(in industriellem Umfeld max 15m)  
(in industrial environment max 15m)

(Kabelstecker von hinten - Lötseite)  
(Connector solder side view)

# Manual MWS 3 & 485-Sensors

## 4.1.2 Allocation of the Connection Cable for Sensors with RS422-port

7 pole connector  
(MWS 3-power supply and data-connection)

Pin 1	(GND)	←—————→	PSU-GND (grey)
Pin 2	(GND - used for MWS 9-5)		
Pin 3	(R+ of MWS 3)	←—————→	wire (yellow)
Pin 4	(T+ of MWS 3)	←—————→	wire (white)
Pin 5	(VCC 18VDC)	←—————→	PSU-VCC (pink)
Pin 6	(R- of MWS 3)	←—————→	wire (green)
Pin 7	(T- of MWS 3)	←—————→	wire (brown)

### MWS Datenkabel RS422 - MWS Datacable RS422

(Stand 07.10.2008)

(alle Ansichten auf die Lötseite - all views onto solder side)

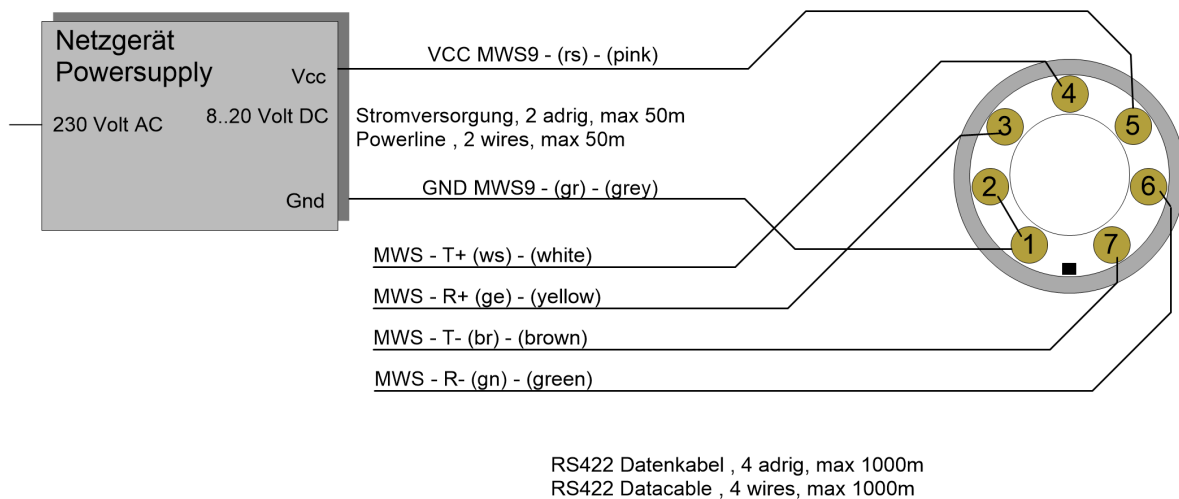

## 5 Excerpts from the Directions of DWD for Automatic Weather Stations

### 2.2 Regulations for Installation

#### 2.2.1 Demands on Location

When you choose a place for the weather station, there must be no impediments, its horizon must be free. Soil and plants must be representative for its surroundings.

For measuring wind it is compulsory that there are no obstacles. Measuring the duration of sunshine especially is based on a free horizon.

When transmitting stations such as directional radio or installations for air traffic control are near, there must be additional shielding.

...

All preventive measures will prove useless if radio medium frequency transmitters are around.

#### 2.2.2 Measuring field

The measuring field ought to be 10 x 10m, but at least 6 x 6m...

### 3. Sensors

#### 3.1 Measuring air temperature 200cm

By standard, air temperature is measured 2m above ground...

In order to keep radiation errors as low as possible, air temperature ought to be measured in a weather hut...

#### 3.4 Measuring relative air humidity 200cm

By standard, relative air humidity is measured 2m above ground...

#### 3.5 Measuring precipitation 100cm

...

The collecting area is 200cm<sup>2</sup>. The Hornersche Wippe (see-saw) tilts when it is filled with 2cm<sup>2</sup>, i.e. 0.1 mm precipitation.

#### 3.7 Measuring windspeed

A cup anemometer is used for measuring wind speed. Its rotational speed is proportional to the horizontal wind speed.

#### 3.8 Measuring wind direction

A wind vane with a perpendicular rotary shaft is used for measuring wind direction. Its orientation in the wind results from the pressure difference on both sides of the vane.

By standard wind direction and wind speed is measured 10m above ground

## 6 Trouble Shooting

If the weather station is placed and mounted as described, there should be no problems in recording data.

When having problems with data transmission, you may decrease the Baud-rate or shorten the cable. You should use low capacitive cable when using cable length over 15m (RS232).

Using the weatherstation in industrial environment can cause big problems in data transmission, when disturbance scatters into the cable.

In this case you should use shielded cable or use RS422 Interface.

(Further hints on the weather CD under FAQs.)

### 6.1 Fault Protocol File (16 bit versions)

Important in case of fault

Whenever you restart the software, all versions of the weather software later than V1.06 create a protocol file of the data transmissions between PC and weather station. With DOS-versions this file is called DIAGNOSE.LOG, with WINDOWS-versions DIAG\_WS.LOG.

This file can help you, so do save it **in any case**, as it is overwritten whenever you restart the software.

Please see the files .DOC or .DOK too. You will find important new information on the weather software which is not yet in this manual.

### 6.2 Protocol-files (32 bit versions)

#### 6.2.1 Log-file in case of error (ErrLog.txt)

Softwareversions for sensors without logger same or newer than V2.26 write a log-file (**ErrLog.txt**) in case of errors (dataerrors or transmission problems), in which the timepoint and kind of the error is stored. Older versions displayed an error-message like **!p** or **data error**, which was displayed permanently until the user clicked it away. This caused the problem that no further data were written for the time the message was visible although the error did not exist any longer.

In version same or newer V2.26 also an error message appears, but this message is deleted automatically when the error is removed. In this case an entry is written into the log-file.

#### 6.2.2 Logfile when starting up (log.dat)

When the software for weatherstations and sensors with logger is started, the communications between the computer and the weatherstation is stored in a log-file (**log.dat**). With this file you may get important hints in case of problems.

**Caution!** This log-file is overwritten each time, when the software is restarted. To keep this file, store it in another place or rename it.  
software.



## 7 Options

More additional modules you can find here:

[http://www.reinhardt-testsystem.de/english/climate\\_sensors/additional\\_modules.php](http://www.reinhardt-testsystem.de/english/climate_sensors/additional_modules.php)

### 7.1 Available displays

#### 7.2.1 Meteograph

Precision analog display with high grade stepping motors.  
For indoor use only.

#### 7.2.2 DKA1

LED mini display for alternating of up to 9 values. 13 mm digit size.

#### 7.2.3 DMMK

Small digital meteo display for displaying 10 parameters simultaneously with digit size 13 mm.  
Available for wall mounting or placing on a table.  
For indoor use only.

## 8 Technical Appendix

### 8.1 Controlling the Microcontroller

#### 8.1.1 Input parameters of MWS 3 / 485-Sensors -Microcontroller

##### Reset

! 'R' <#13>

##### Changing the BAUD-Rate:

! 'B' <X> <#13> ; 0 < X < 8 :

BAUD-Rate for X =	0	:	1200	
	1	:	1200	
	2	:	1200	
	3	:	2400	
	4	:	4800	
	5	:	9600	(Default)
	6	:	19200	
	7	:	38400	
	8	:	4800	

##### Input-flags for control, !Fx, 0 <= x <= 255

Bit 7 - not available  
Bit 6 - Output of device address (DA) with <CR><LF> in front of every data record  
Bit 5 - on: Reset of GE input with !R, off: Reset of GE input with !P  
Bit 4 - not available  
Bit 3 - not available  
Bit 2 - not available  
Bit 1 - not available  
Bit 0 - not available

##### Changing from measured value output and adjustment mode (output of frequency):

! 'W' <#13>

##### *Fading in/out single sensors (All available sensors are listed on a following page.)*

! 'KX,A0' <#13> ; No output of sensor with output-number X

! 'KX,A1' <#13> ; Output of sensor with output-number X

##### *Sensor attenuation for turn sensor on / off*

! 'KX,M0' <#13> ; Sensor with output-number X is not attenuated

! 'KX,M1' <#13> ; Sensor with output-number X is attenuated

## Transmitting linearisation data:

"! 'L' <SENSORNUMBER> ',' <INDEX : 1..5> ','  
'F' <VOLTAGE(mV)> <#13>  
(only valid for ZA and ZB)

"! 'L' <SENSORNUMBER> ',' <INDEX : 1..5> ','  
'W' <ANALOGVALUE> <#13>  
(only valid for ZA and ZB)

"! 'L' <SENSORNUMBER> ',' 'L' <Linearity factor> <#13>  
(depends on the respective sensor)

"! 'L' <SENSORNUMBER> ',' 'S' <Linearity summand> <#13>  
(depends on the respective sensor)

"! 'L' <SENSORNUMBER> ',' 'O' <Temperature offset> <#13>  
(depends on the respective sensor)

"! 'L' <SENSORNUMBER> ',' 'T' <Temperature coefficient> <#13>  
(depends on the respective sensor)

## Setting local altitude for display of barometric pressure

"! 'O' <LOCALALTITUDE(m)> <#13>

## Resetting windpeak and average wind

"! 'P' <#13>

## Toggle between outputmode and Securemode

'!"' <#13>



(SECURE-Mode: no measurement, no value output, only output of **\*\*SECURE\*\***)

In SECURE-mode no address is needed for commands, even when the sensor is set to RS485 mode!!  
The EEPROM-write protection can be disabled in secure mode.

## Setting a delay for execute after receiving a command

"! 'SW<sub>x</sub>' <#13>

where x is a delay from 1..255 milli seconds. Default is 5 ms.



## Turning on / off the interface (Protocol-Select)

**ATTENTION: THESE SETTINGS ARE VERY CRITICAL !!**

**In the event of incorrect operation, the sensor can be adjusted irreparably.**

**An incorrect change of this parameter, which leads to a repair, is excluded from the guarantee !!.**

!'SX' <#13> Suppresses the data output to the interface  
**X is the decimal value of the following binary list for the various protocols.**

Binary list of the protocol-parameter for X.

X (binary) =

xxxxxx00b : RS232 - MWS 3 transmits a data record every sec  
xxxxxx01b : RS422 - MWS 3 transmits a data record every sec  
xxxxxx10b : RS485 - MWS 3 is addressed and transmits on request  
xxxxxx11b : not available  
xxxxx1xxb : MWS 3 transmits on request only (RS232 + RS422)  
xxxx1xxx b : not available  
xxx0xxxxb : not available  
xxx1xxxxb : not available  
xx1xxxxxb : not available  
1xxxxxxxb : EEPROM write protection  
(can only be disabled in SECURE-mode!)

By combination (addition) of single binary values, you can combine the parameters.

Example for MWS9-5 with RS422 transmits on request only :

X for RS422 (binary) = xxxxxx01

X for transmits on request (binary) = xxxxx1xx

adds --> = xxxxx101 --> Decimal = 5 --> !S5<#13>

CAUTION: With RS485 after the ! or ? always the device address must be inserted! Other ways the command won't be accepted! (Standard@ = 1)

## 8.2.2 Querying the Microprocessor

**Call the current data file:**

'?' 'U' <#13>

**Call linearisation data, sensor configuration and system information:**

!' '?' <#13>

**Call linearisation data for an explicit sensor:**

!' '?0' <#13>

Only the info about the main configuration will be sent.

!' '?1' <#13>

Only the info about the configuration of the sensors will be sent.

!' '?2' <#13>

Only the info about the sensor 2 (temperature) will be sent.

...and so on.

## 8.2.3 Order of the MWS 3 sensors

<i>Output-#</i>	<i>Sensor-#</i>	<i>Sensor-ID</i>	<i>Sensor</i>	<i>Default (MWS3)</i>	<i>Unit</i>
1	0	---	Pseudo-time	off	
2	1	TD	Temperature of pressure sensor	on	[°C]
3	2	TE	Temperature	on	[°C]
4	3	ZA	Additional 1	off	[mV]
5	4	DR	Pressure	on	[hPa]
6	5	RE	Rain (wind input)	off	[mm] / [l/m <sup>2</sup> ]
7	6	GE	Counter (wind input)	off	[ ]
8	7	WG	Wind speed	on	[km/h]
9	8	WR	Wind direction	on	[°]
10	9	ZB	Additional 2	off	[mV]
11	10	FE	Humidity	on	[%]
12	11	WS	Wind peak	on	[km/h]
13	12	WD	Wind average	on	[km/h]
14	13	OH	Altitude	off	
15	14	LX	Light intensity	off	[lux]

Caution: The pressure sensor uses the sensor "Temperature of pressure sensor" (TD) for compensating the temperature drift of pressure sensor. Don't disable this sensor! Otherways the pressure cannot be measured correctly!

The number of sensors and the identifiers in the data string depend on the kind of sensor you ordered.

### Other possible identifiers:

SO - global radiation in [W/m<sup>2</sup>].

SI - global radiation in [W/m<sup>2</sup>] integrated (strongly attenuated and with lower resolution as SO

UV - UV-A radiation in [mW/m<sup>2</sup>]

UI - UV index (unitless)

UD - UV index (unitless) integrated (strongly attenuated and with lower resolution as SO

WU - cloud base in [m].

WK - cloudiness yes (1) / no (0) (unitless)

RD - Precipitation per storage interval in [mm] / [l/m<sup>2</sup>]



## 9 Exchange Connectors

In case you have to replace connectors, please contact:

Fa. Adam, Tel: ++49 (0)8131 - 2808 51

The connectors belong to Series 711.

Below you will find the order numbers:

5way connector (heating / GPS) : **99-0095-102-05**

7way connector (data and power-supply) : **99-0475-102-07**

8way connector (additional sensors) : **99-0479-102-08**

Of course, you can order the connectors also from REINHARDT.

*I&OE / Specifications subject to change without prior notice !*  
06/23